

Specification 5540 5544

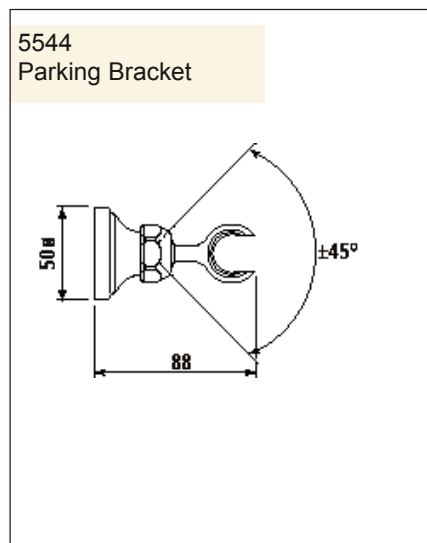

Sliding Rail & Parking Bracket

- Vernier insert for accurate handle alignment
- Concealed Fixing

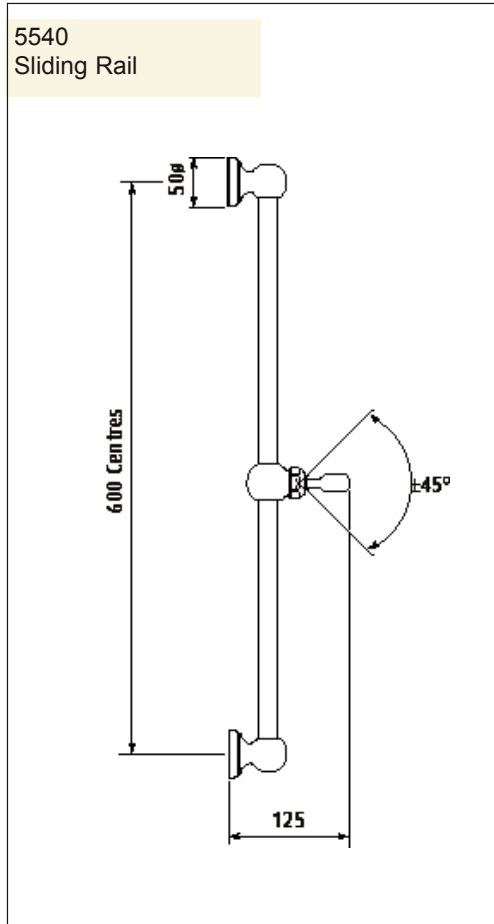

Packed Weight: 5540 1.8Kg

5544 0.3Kg

Temp Range:

Min 1°C / 34°F

Max 85°C / 185°F

Recommended working pressure:

Min 0.5 bar / 7psi

Max 5 bar / 75 psi

Specification 5540 5544



Sliding Rail & Parking Bracket

- Vernier insert for accurate handle alignment
- Concealed Fixing

Where * Indicated Specify Colour.

