

Specification 5555

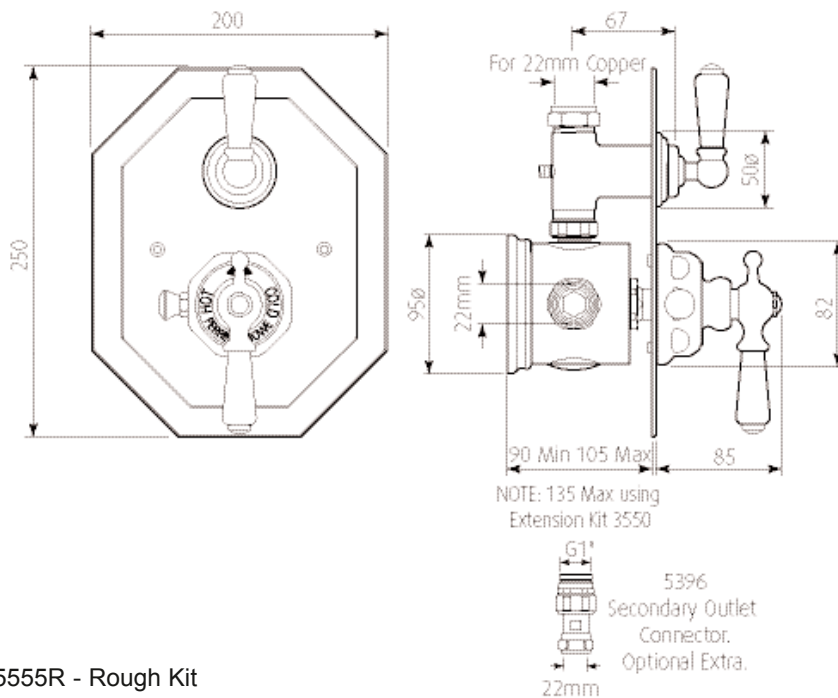

Concealed Dual Control Thermostatic Shower Mixer

- Wax capsule thermostatic cartridge with 1 second supply failure response
- Separate temperature and flow levers • 1/4 turn ceramic disc flow control
- Adjustable temperature safety override stop (pre-set to 38°C)
- G 3/4" inlets fitted with non return valves and strainers



5555R - Rough Kit

5555T - Trim Kit

Packed Weight: 6.4Kg

Rough Kit 3.8Kg

Trim Kit 2.7Kg

Temp Range:

Min 18°C / 52°F

Max 49°C / 118°F

Temp Stability:

± 1°C / ± 1.8°F

Max Inlet Temp:

82°C / 180°F

Recommended working pressure:

Min 0.5 bar / 7psi

Max 5 bar / 75 psi



Specification 5555



Concealed Dual Control Thermostatic Shower Mixer

- Wax capsule thermostatic cartridge with 1 second supply failure response
- Separate temperature and flow levers • 1/4 turn ceramic disc flow control
- Adjustable temperature safety override stop (pre-set to 38°C)
- G 3/4" inlets fitted with non return valves and strainers

Where * Indicated Specify Colour.

