

# Specification 4173

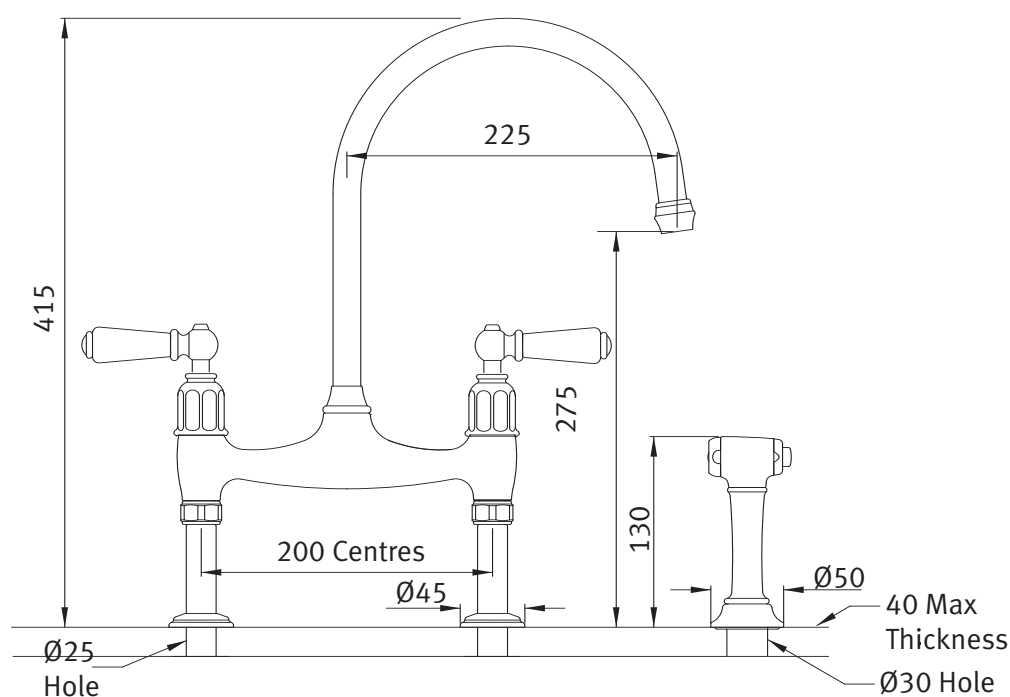

## Ionian Two Hole Sink Mixer with Lever Handles and Rinse

- 1/4 turn ceramic disc flow control. ● vernier insert for accurate handle alignment.
- unique handle construction with integral bearing ring.



**Temp Range:**  
min 1C/34F  
max 85C/185F

**Recommended working pressure:**  
min 1 bar/15psi  
max 5 bar/75psi



# Specification 4173



## Ionian Two Hole Sink Mixer with Lever Handles and Rinse

- 1/4 turn ceramic disc flow control. ● vernier insert for accurate handle alignment.
- unique handle construction with integral bearing ring.

Where \* Indicated Specify Colour.

