

Specification 4360

Phoenician Monobloc Mixer with Porcelain Lever Handles and Rinse

- 1/4 turn ceramic disc flow control. ● vernier insert for accurate handle alignment.
- unique handle construction with integral bearing ring. ● flexible connectors for easier installation.
- pull out rinse with insulated handle. ● Corian available.

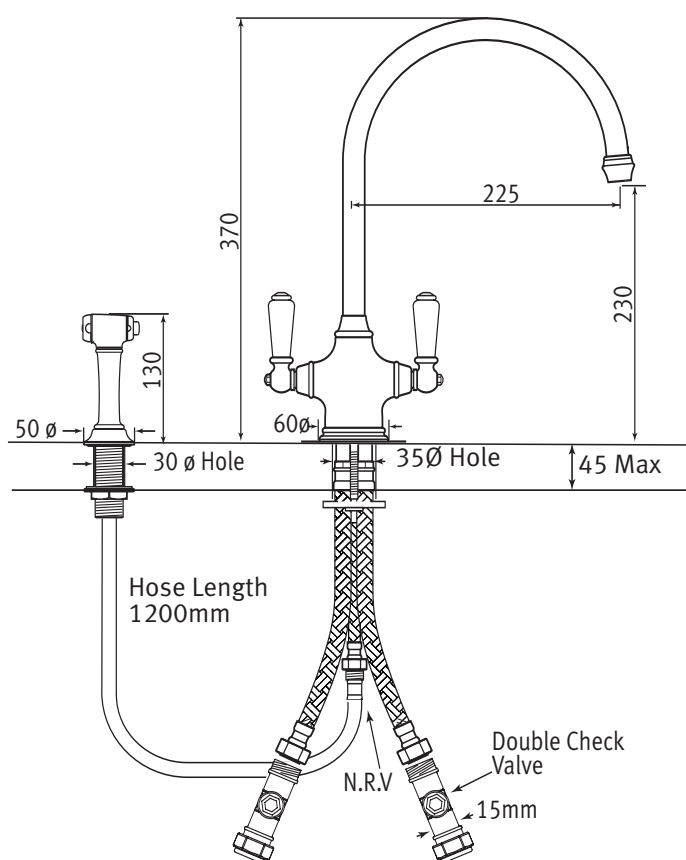

Packed Weight: 3.6kg

Temp Range: min 1°C/34°F max 85°C/185°F

Recommended working pressure:

min 1 bar/15 psi max 5 bar/75 psi



Specification 4360

Phoenician Monobloc Mixer with Porcelain Lever Handles and Rinse

- 1/4 turn ceramic disc flow control. ● vernier insert for accurate handle alignment.
- unique handle construction with integral bearing ring. ● flexible connectors for easier installation.
- pull out rinse with insulated handle. ● Corian available.

Where * Indicated Sp

