

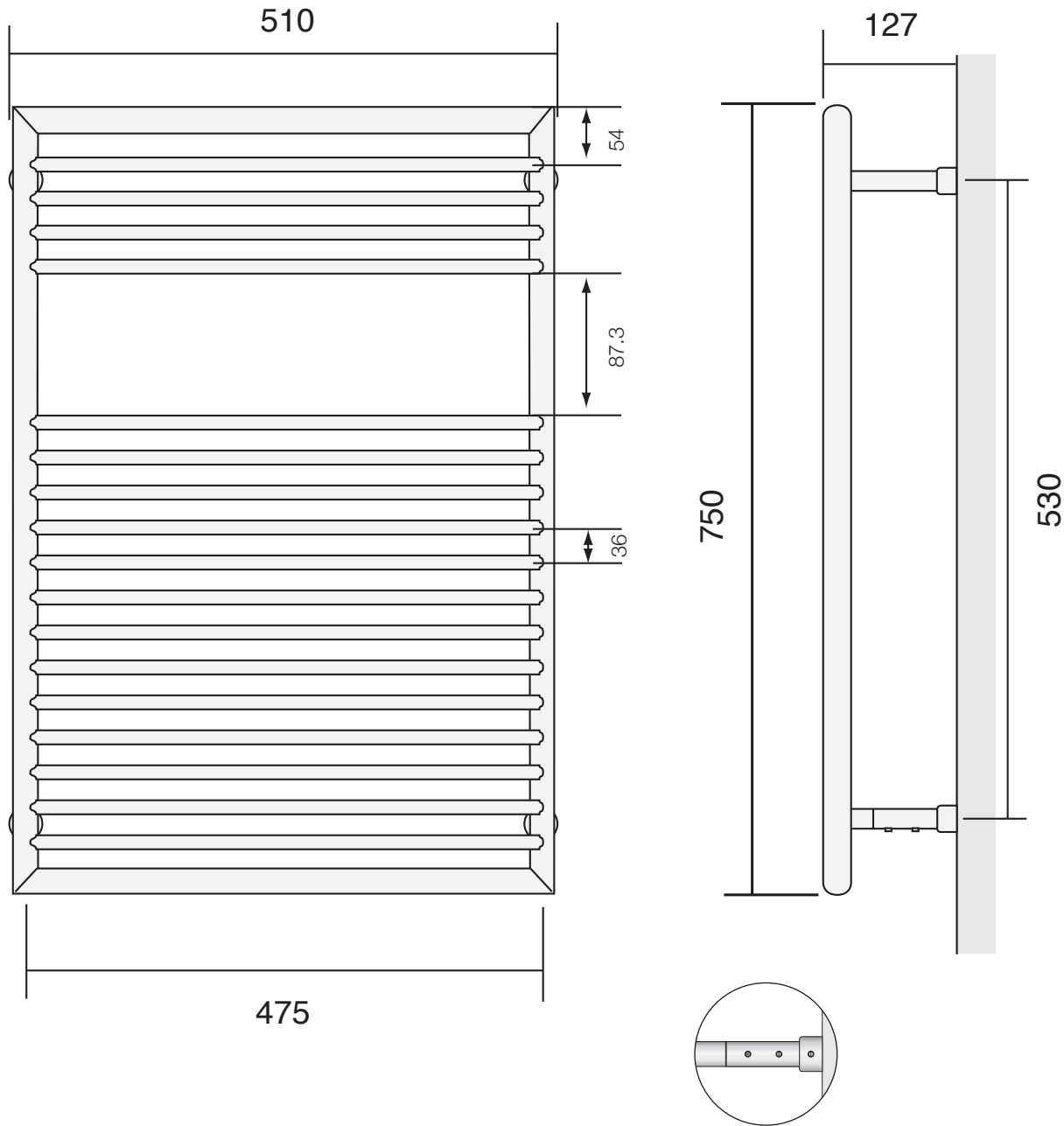

All dimensions are in mm and may vary + - 5mm as they are hand made, hand soldered and polished



Enlarged image of concealed valve

Test pressure: **6 BAR**

Max working pressure: **3 BAR**

Max working temperature: **100° C**

Connections: **15mm compression**

Heat output determined in accordance with EN 442

Btu/hr @ Delta 60: **1050**

Overall height: **750**

Width over flange: **510**

Overall projection: **127**

Pipe centre for valves: **475**

Tube Ø mm: **25**

Bard & Brazier rails are made in England from high quality brass and can be used on open or closed circuits



All dimensions are in mm and may vary + - 5mm as they are hand made, hand soldered and polished

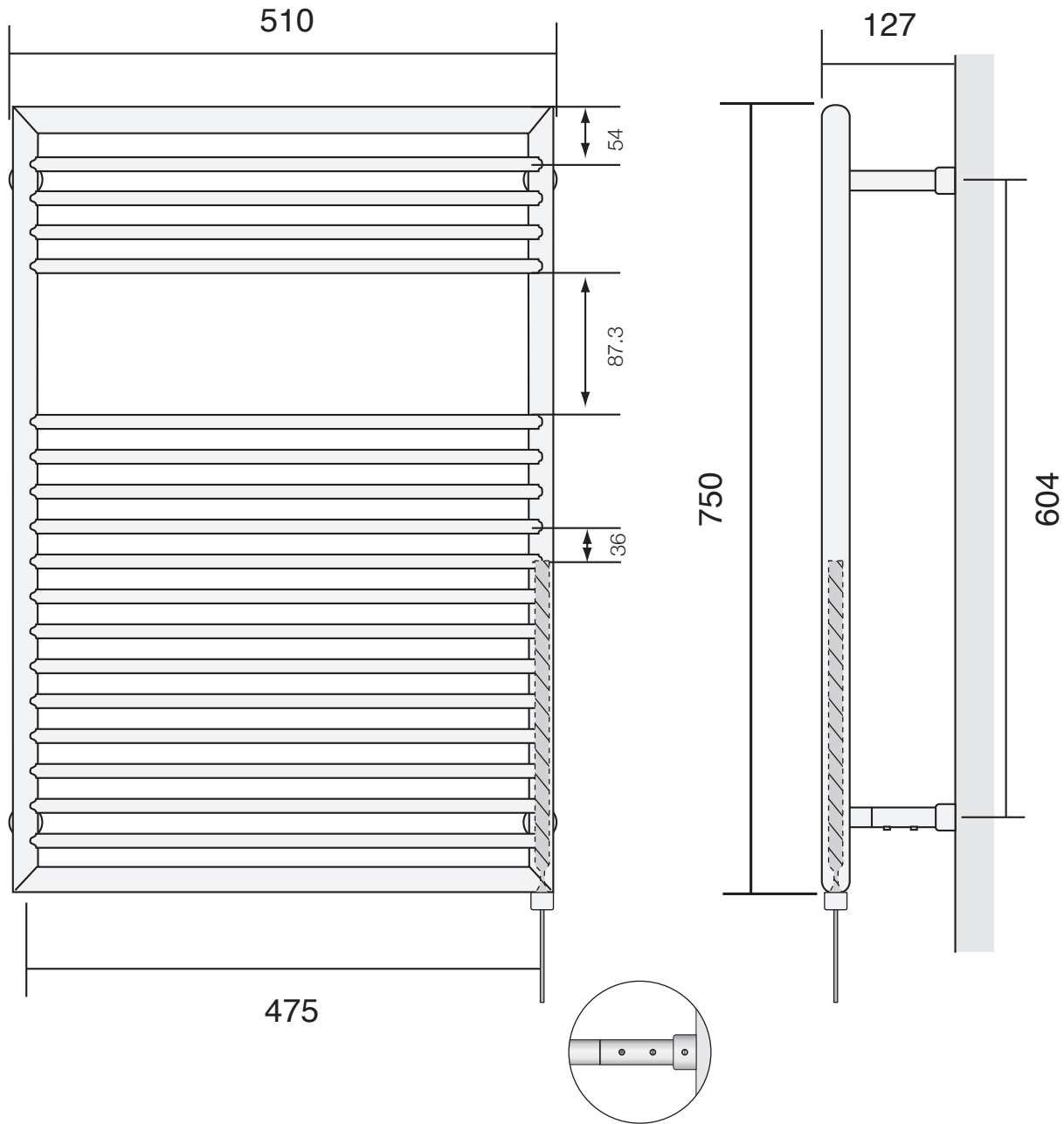

Enlarged image of concealed valve

Test pressure: **6 BAR**  
 Max working pressure: **3 BAR**  
 Max working temperature: **100 °C**  
 Connections: **15mm compression**  
 Electric element: **Right hand**  
 Heat output determined in accordance with EN 442

Btu/hr @ Delta 60: **1050**  
 Electric element wattage: **125**  
 Overall height: **750**  
 (Approx 105mm required in addition for element)  
 Width over flange: **510**  
 Overall projection: **127**  
 Pipe centre for valves: **475**  
 Tube Ø mm: **25**

Bard & Brazier rails are made  
 in England from high quality brass  
 and can be used on open or closed  
 circuits