

LB 4018
CLASSIC TORCH WALL LAMP
INSTALLATION GUIDE

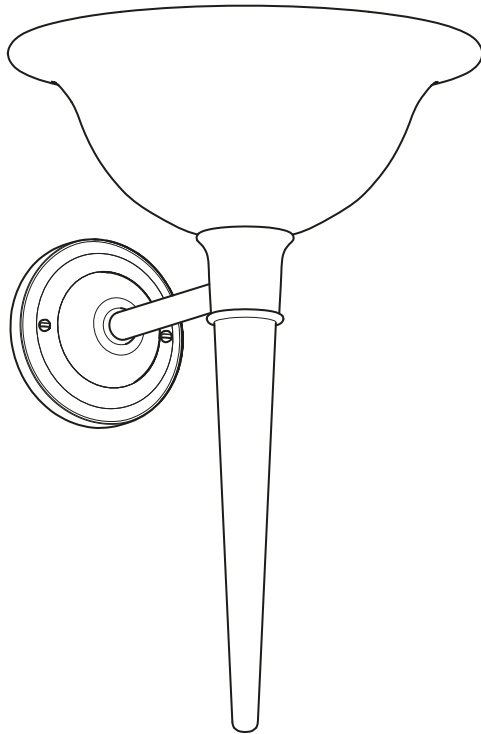

LEFROY BROOKS

IMPORTANT INFORMATION

1 Switch off your power supply at the fuse box (consumer unit). This can be achieved in two ways. The first is to turn off the miniature circuit breaker (MCB) for the lighting circuit and place RED insulating tape over the MCB to prevent it being accidentally turned on. The second is to turn off the main switch, remove the circuit fuse and turn the main switch on again to restore power to the rest of the house.

2 Colour code for fixed wiring:

GREEN & YELLOW – Earth



BROWN – Live

(Live wires can also be RED)



BLUE – Neutral

(Neutral wires can also be BLACK)





BLUE with brown sleeve – Switch wire with sleeve

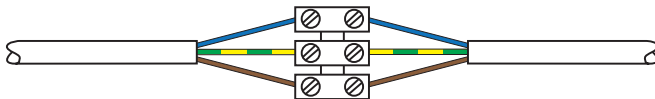

NOTE: Some lamps may have a clear cable. In this case, the earth wire will be marked with a green & yellow thread.

3 CLASS I Lamps (Earthed) – Connect the brown wire from the lamp to the supply live wire (red or brown). Connect the blue wire to the supply neutral wire (black or blue). Connect the green & yellow wire to the supply earth wire (green & yellow) or connect the supply earth to the lamp earth terminal marked with the symbol 



4 CLASS II Lamps (Not earthed) – These lamps are double insulated and have the symbol . These fittings do not have to be connected to the supply earth. Make sure that the basic insulation of the supply wiring cannot contact touchable metal. Connect the brown wire from the lamp to the supply live wire (red or brown). Connect the blue wire to the supply neutral wire (black or blue). Isolate the supply earth wire.

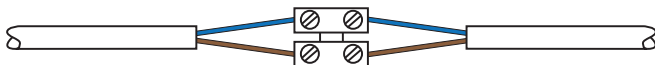

Silicone sleeving may be fitted to protect the supply cable from heat. Fit the sleeving over the supply cable up to the terminal block or lamp holder or to at least the mounting surface.

DIMENSIONS

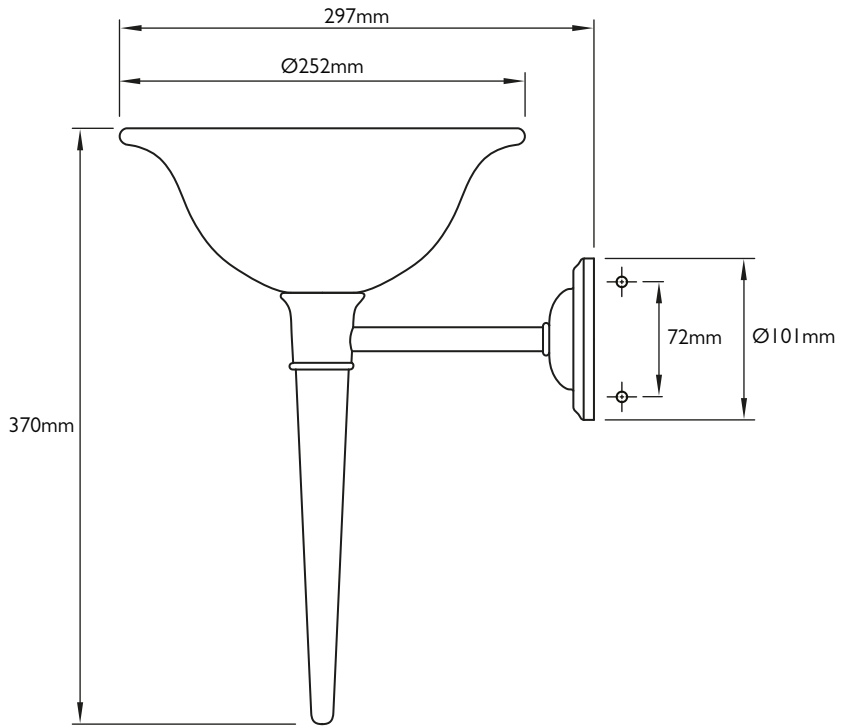

INSTALLATION

- I Unscrew and remove the two screws from the front of the lamp. This will release the mounting plate at the rear.

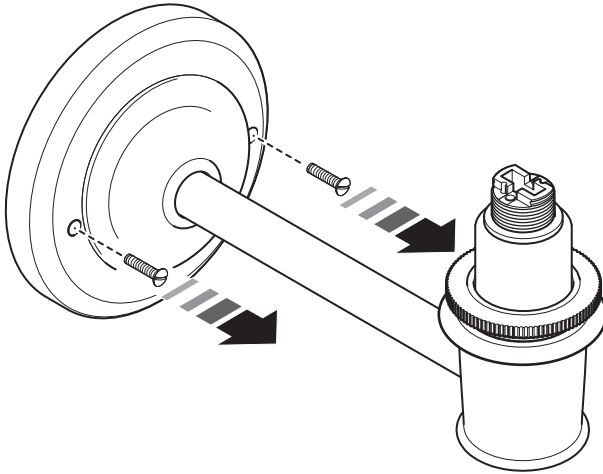

INSTALLATION

- 2 With the raised screw holes facing you, place the mounting plate against a suitable mounting surface. Using a spirit level, ensure that the raised screw holes are horizontal. Mark the location of the two slotted holes on the mounting surface. Drill two suitable holes for the required fixings. Wall plugs and screws are supplied with the lamp. Feed the supply cable through the central hole in the mounting plate. Secure the mounting plate using suitable fixings.

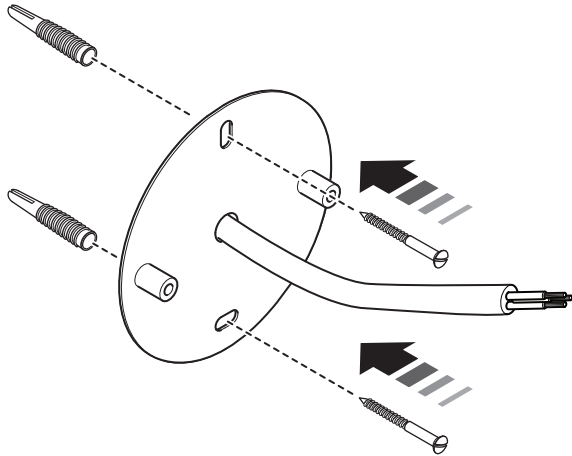

INSTALLATION

- 3 Connect the cable to the junction box at the rear of the lamp.
- 4 Secure the lamp to the mounting plate using the two screws previously removed.

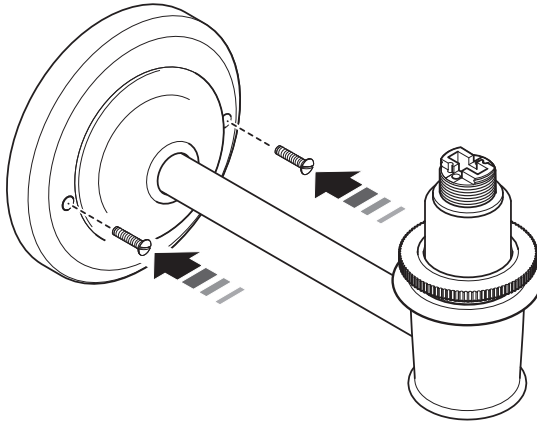

- 5 Unscrew and remove the circular shade retainer from the lamp.

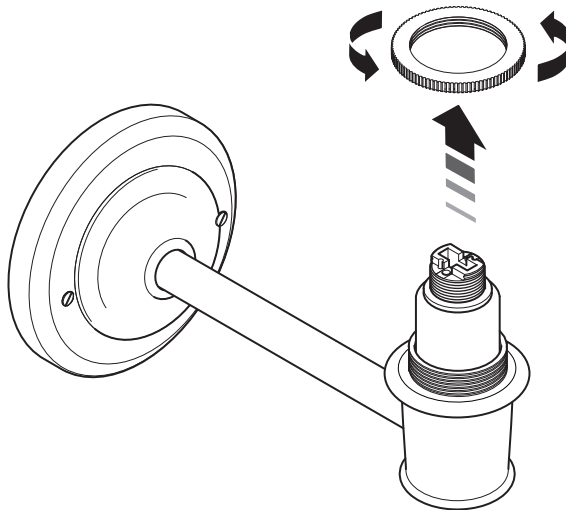

INSTALLATION

- 6 Locate and screw the stem of the lamp in place.

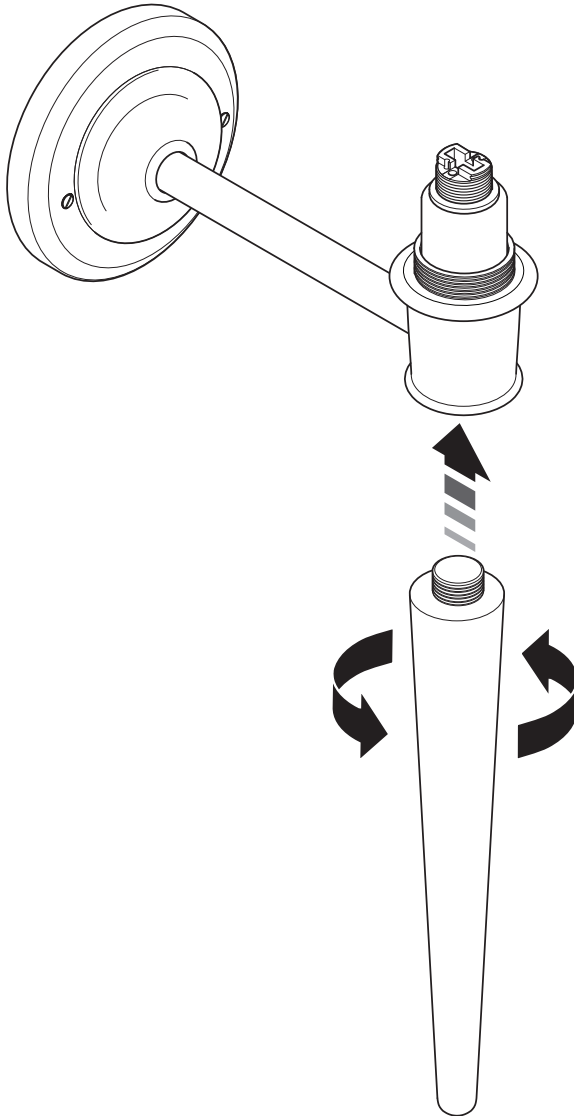

INSTALLATION

- 7 Place the shade over the bulb housing.

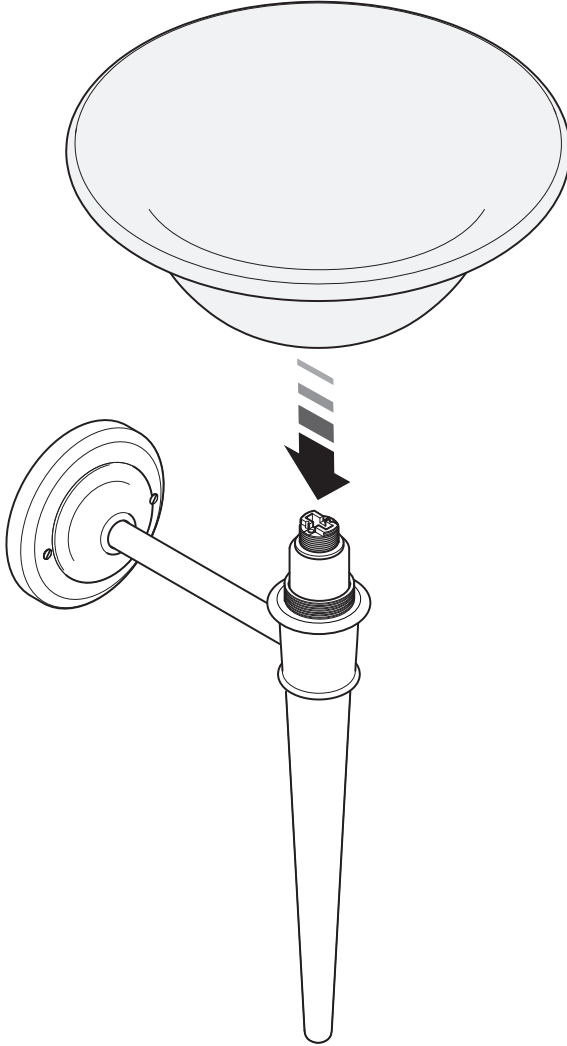

INSTALLATION

- 8 Rest the rubber seal inside the shade around the housing.
- 9 Screw the shade retainer in place to secure the shade. Be careful not to over-tighten the retainer as this will damage the shade.

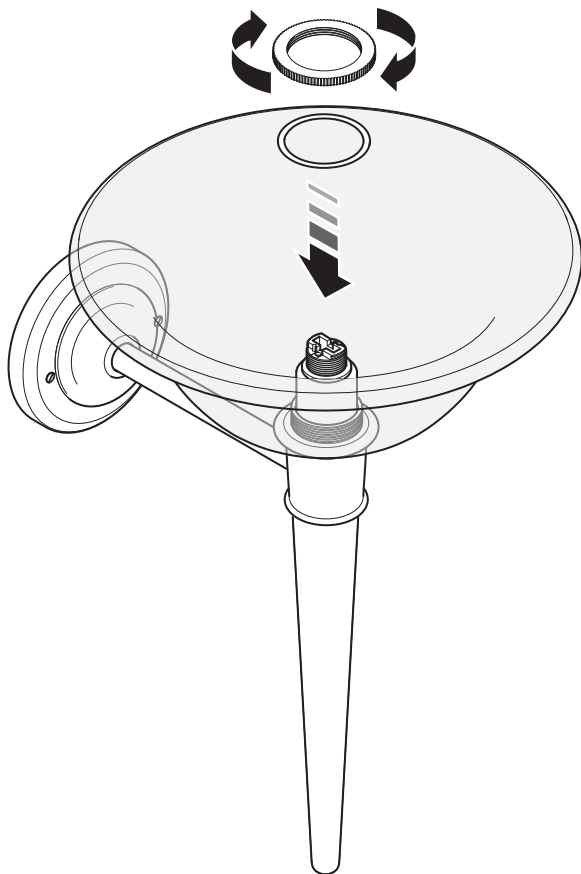

INSTALLATION

10 Gently push the bulb in place before screwing the protective shroud onto the housing.

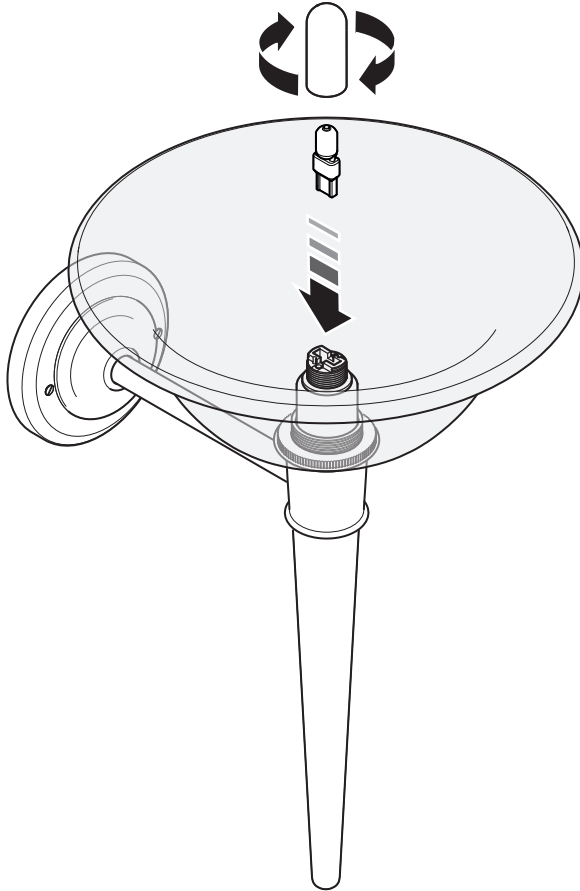

SERVICING

Replacing the bulb

- 1 Switch off your power supply at the fuse box (consumer unit). This can be achieved in two ways. The first is to turn off the miniature circuit breaker (MCB) for the lighting circuit and place RED insulating tape over the MCB to prevent it being accidentally turned on. The second is to turn off the main switch, remove the circuit fuse and turn the main switch on again to restore power to the rest of the house.
- 2 Unscrew and remove the protective shroud that covers the bulb.
- 3 Gently pull the bulb from the holder.
- 4 Fit a replacement bulb (220-240V G9 3.5 Watt LED).
- 5 Fit the protective shroud.

Refer to illustration on page 10



CUSTOMER SERVICE DIRECT LINE

+44 (0)1902 390 894

customerservices@lestroybrooks.co.uk

LEFROYBROOKS.CO.UK

Whilst every effort is made to ensure the accuracy of these, they are subject to change without notice as part of the company's product development process. The use of trademarks, product design and artwork is subject to licence or agreement with LBIP Ltd. The design registrations, trademark registrations and copyrights are protected by law and the use or reproduction outside the terms of an agreement is prohibited. The right to modify designs and dimensions is reserved. LBIP Ltd is a member of ACID (Anti Copying in Design). E&OE